

Applications

HD-5080

The HD-5080 features a rectangular mouth geometry ideal for applications where wide horizontal coverage is required as well as controlled and limited vertical coverage. This rectangular coverage is particularly suited for indoor applications where floor and ceiling reflections must be minimized to prevent a poor ratio of direct to reflected energy.

The P Audio HD-5080 uses the very reliable PA-D110 compression driver in a reentrant wide band horn design. The system is available in both 8 ohm and 16 ohm impedance versions. The 16 ohm version is ideal when multiple paging horns must be used to cover increased areas. The system is provided with an integral mounting bracket for fast and easy installation.

The system is weather resistant and is an ideal choice for small to medium format vocal range installations.



Specifications

Nominal Impedance	8 or 16 Ohm
Power	75 Watt
Sensitivity	Over 120 dB
Frequency Response	200 Hz – 5 kHz
Nominal Coverage Angle (H x V)	60° x 40°
Dimension	380mm x 252mm x 400mm 14.9" x 9.9" x 15.7"
Finish Color	Dark Gray
Component	1 x PA-D110
Construction	Press Aluminum
Unit Weight	3.4 kg (7.5 lbs)
Shipping Weight	4.0 kg (8.8 lbs)
Packing Dimension HxWxD (cm)	38 x 27 x 45 (1.7 cu.ft)

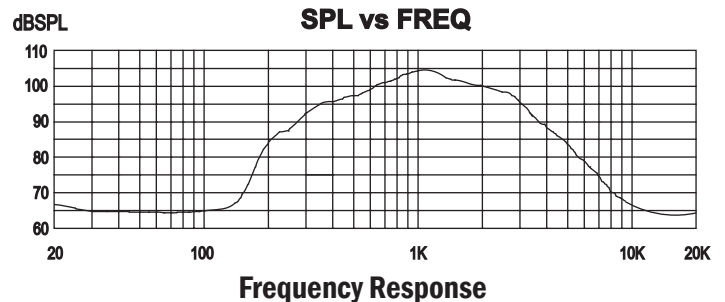
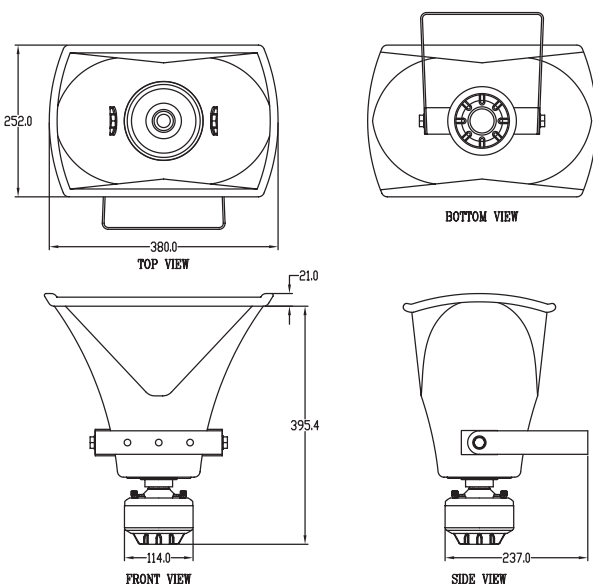

19/4 Moo 2 T.Bangkratuk A. Samparn Nakornpathom 73210 Thailand
 Tel: +66-2-441-6600 Auto 30 Lines
 e-mail: info@paudiothailand.com
 Web site: www.paudiothailand.com
 All rights reserved by P.Audio System Co., Ltd. 2007

